



Floor spring

DORMA **BTS 84**

The economic double action floor spring

Special shallow design optional hold-open.

The DORMA BTS 84 is a double action floor spring which has been specially developed for the aluminium and toughened glass door industries.

This unit is intended to complement our internationally acclaimed RTS concealed overhead door closer by giving the shop-fitting industry the option of a DORMA quality floor spring designed for their particular purpose.

The BTS 84 has many of the features of the other DORMA BTS closers with the addition of reduced depth and an array of accessories designed for the aluminium door fabricator and toughened glass door manufacturer.

Certified to ISO 9001.

Plus points

For the trade

- Outstanding value for money.
- Also available with stronger and weaker springs for special requirements.

For the installer

- Easy installation thanks to shallow design.
- Easy to adapt to individual requirements with dual valve control 130° to 0° and 130° to 20°.
- Interchangeable spindle inserts available to suit site conditions.

For the architect/specifier

- Concealed unit for invisible installation.
- Minimum floor recess dimension.
- Proven, robust unit for door weights up to 100 kg.

For the user

- Thermoconstant smooth operation.
- High mechanical efficiency for easy door opening.
- Optional single point hold-open

Technical Data	BTS 84		
	EN 2	EN 3	EN 4
Spring strength			
Standard and external doors ^{1) 2)}	●	–	–
up to 850 mm	–	●	–
up to 950 mm	–	–	●
up to 1100 mm			
Closing speed variable by valve adjustment	●	●	●
Backcheck	–	–	–
Delayed action	–	–	–
Hold-open point	90°	○	○
Weight in kg, approx.	5.0	5.0	5.0
Dimensions in mm			
Length	306	306	306
Width	108	108	108
Height	40	40	40
Door closer tested to EN 1154	●	●	●
CE mark for building products (products with factory-fitted hold-open do not carry a CE mark)	–	●	●

● Yes – No ○ Option

¹⁾ For applications involving particularly high or heavy doors, and doors which have to close against wind or draught conditions, the next larger closer size or the DORMA BTS 80 should be selected.

²⁾ Max. opening 130°. Door stop necessary for doors which can open further than 130°.

- 1 Valve for closing speed adjustment 130° – 0°
- 2 Valve for increasing closing speed 130° – 20°

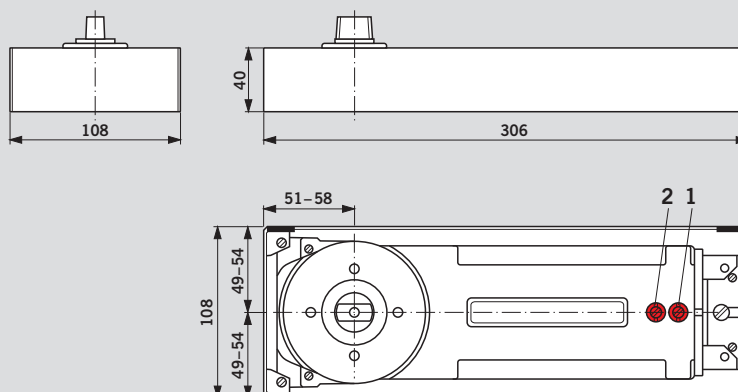

Standard and optional functions

Closing ranges

The floor spring has two controlled closing ranges:
 Valve 1: 130° – 0° sweep
 Valve 2: Increases the closing speed between 130° and 20°.

Hold-open

With the hold-open (optional extra), the door can be held at an angle of 90°.

- 1 First adjusting closing range (130° – 0°)
- 2 Second adjusting closing range (130° – approx. 20°)
- 3 Hold open at 90° (optional extra)

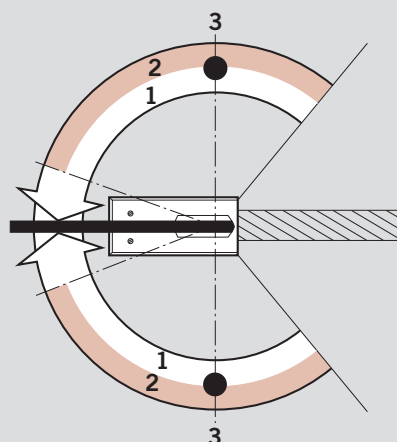

Accessories

Applications and fixing instructions, door straps and top centres

See Technical Information "Floor spring accessories".

Extended spindle insert

Spindle Extension	Dimension "X" (Door Clearance)
Standard	8 mm
5 mm	13 mm
7.5 mm	15.5 mm
10 mm	18 mm
12.5 mm	20.5 mm
15 mm	23 mm
20 mm	28 mm
25 mm	33 mm
30 mm	38 mm
35 mm	43 mm
40 mm	48 mm
45 mm	53 mm
50 mm	58 mm

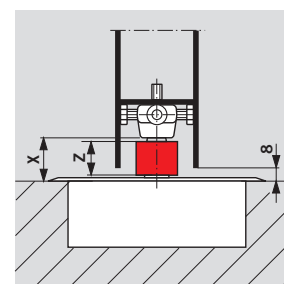
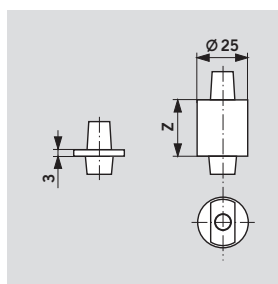

NOTE: Closer and bottom strap must be installed per fixing instructions for door clearances shown to be valid. Closers with extended spindle inserts are used with thresholds, carpeted floors, terazzo pans or in cases where more clearance between door and floor is required. Surface finish: Zinc plated.

DORMA 2300 Sealing Compound
 For filling the cavities between the floor spring body and the cement box to prevent moisture penetration (mandatory according to e.g. VOB regulations for wet rooms).

Universal cover plate

available in stainless steel or satin brass.

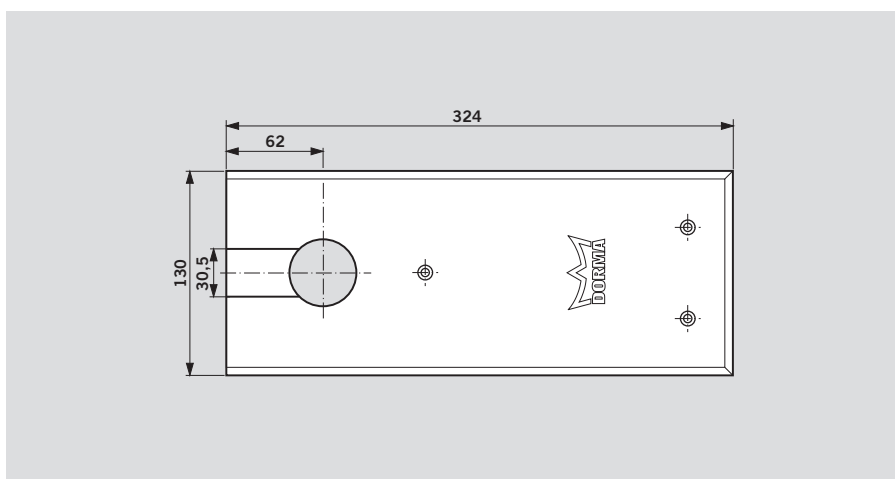

Options and accessories

Floor spring BTS 84 including cement box and standard spindle insert	Floor spring BTS 84 including cement box without spindle insert	Extended spindle inserts (extension in mm)														Universal cover plate		Sealing compound 2300 0.5 kg 45090059
		0	5	7,5	10	12,5	15	20	25	28	30	35	40	45	50	Stainless steel	Satin brass	
		45200401	45200402	45200403	45200404	45200419	45200405	45200406	45200407	45200414	45200408	45200409	45200410	45200411	45200412	46700022	46700023	
Standard																		
EN 2 81125002	EN 2 81125001	#	#	#	#	#	#	#	#	#	#	#	#	#	#	#	#	#
EN 3 81110002	EN 3 81110001	#	#	#	#	#	#	#	#	#	#	#	#	#	#	#	#	#
EN 4 81100002	EN 4 81100001	#	#	#	#	#	#	#	#	#	#	#	#	#	#	#	#	#
with hold-open 90°																		
EN 2 81225002	EN 2 81225001	#	#	#	#	#	#	#	#	#	#	#	#	#	#	#	#	#
EN 3 81210002	EN 3 81210001	#	#	#	#	#	#	#	#	#	#	#	#	#	#	#	#	#
EN 4 81200002	EN 4 81200001	#	#	#	#	#	#	#	#	#	#	#	#	#	#	#	#	#

= Accessory

Specification text

Floor spring for double action doors, with hydraulic fully controlled closing from approx. 130°; including cement box and removable spindle insert.

Size

- EN 2
 EN 3
 EN 4

Models

- Standard
 Hold-open 90°

Accessories

- Universal cover plate
 Stainless steel
 Satin brass
 Extended spindle insert, . . . mm extended
 Sealing compound

Make: DORMA BTS 84
Division Door Control worldwide
www.dorma.com
Central Europe

DORMA GmbH + Co. KG
DORMA Platz 1
D-58256 Ennepetal
Tel. +49 2333 793-0
Fax +49 2333 793-495

Australasia

DORMA Door Controls Pty. Ltd.
46-52, Abbott Road
Hallam/Victoria 3803
Australia
Tel. +61 3979 63555
Fax +61 3979 63955

China/Hong Kong

DORMA Door Controls
(Suzhou) Co. Ltd.
No. 9, Hong Feng Road
Suzhou Singapore Industrial Park
Suzhou, 215021
P.R. of China
Tel. +86 512 67612481
Fax +86 512 67614582
DORMA Door Controls Pte. Ltd.
Room 701, Technology Plaza
651 King's Road
North Point
Hong Kong
Tel. +852 25034632
Fax +852 28875370

Emerging Markets

DORMA GmbH + Co. KG
DORMA Platz 1
D-58256 Ennepetal
Tel. +49 2333 793-0
Fax +49 2333 793-495

DORMA Door Controls (Pty.) Ltd.

Kings Court
4A Mineral Crescent
ZA-2000 Crown/Gauteng
South Africa
Tel. +27 11 8300280
Fax +27 11 8300291

Far East

DORMA Far East Pte. Ltd.
No. 31 Gul Lane
Singapore 629425
Tel. +65 6268 7633
Fax +65 6265 7995

France

DORMA France S.A.S.
Europarc
42, rue Eugène Dupuis
F-94046 Créteil
Tel. +33 1 41942400
Fax +33 1 41942401

Gulf

DORMA Gulf Door Controls FZE
Jebel Ali Free Zone South
Plot No. S 20135
Road No. SW 301 G
P.O. Box 17268
Dubai – United Arab Emirates
Tel. +971 4 8020400
Fax +971 4 8869100/8869101

North America

DORMA Architectural Hardware
DORMA Drive, Drawer AC
Reamstown, PA 17567-0411
Tel. +1 800 5238483
Fax +1 800 2749724

Scanbalt

DORMA Sverige AB
F O Petersons Gata 24
SE-421 31 Västra Frölunda
Tel. +46 31 289520
Fax +46 31 281739

South America

DORMA Sistemas de Controles
para Portas Ltda.
Av. Piracema, 1400
Centro Empresarial Tambore
CEP 06400-933 Barueri/
São Paulo, Brasil
Tel. +55 11 46899280
Fax +55 11 46899215

South-East Europe

DORMA AUSTRIA GmbH
Pebering Strass 22
A-5301 Eugendorf
Tel. +43 6225 284880
Fax +43 6225 28491

South Europe

DORMA Italiana S.r.l.
Via. Canova 44/46
I-20035 Lissone (MI)
Tel. +39 039 244031
Fax +39 039 24403310
DORMA Ibérica, S.A.
Camino San Martin de la Vega, 4
E-28500 Arganda del Rey
(Madrid)
Tel. +34 91 8757850
Fax +34 91 8757881

UK/Ireland

DORMA UK Ltd.
Wilbury Way
Hitchin
GB-Hertfordshire SG4 0AB
Great Britain
Tel. +44 1462 477600
Fax +44 1462 477601

